

JIS 5K Can WATER filter
JIS 10K Can WATER filter

JIS F7121
JIS F7121

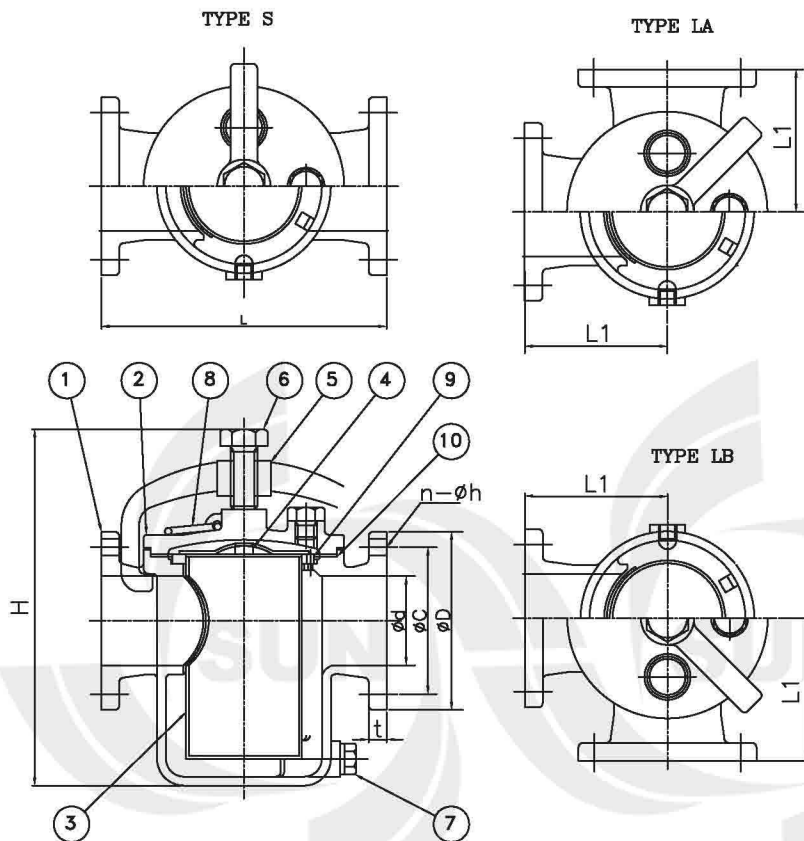

NO.	PARTS	MATERIAL
1	BODY	CAST IRON
2	COVER	CAST IRON
3	STRAINER CYLINDER	STEEL / STAINLESS STEEL
4	STRAINER HANDLE	STEEL / STAINLESS STEEL
5	COVER PUSHER	DUCTILE IRON / STEEL
6	PUSHING BOLT	STEEL / BRASS
7	PLUG	BRASS
8	HANDLE OF COVER	STEEL
9	SET SCREW	STEEL / STAINLESS STEEL
10	GASKET	RUBBER

Test Pressure (MPa)

Rating	JIS 5K	JIS 10K
Hydrostatic press test (Shell)	0.3	0.3

Dimension Table

(Unit : mm)

Rating	Size	ød	øD	øC	N-øh	t	L	L1	H	Weight (kg)
JIS 5K (JIS F7121)	25A	25	95	75	4-12	14	170	85	180	5.08
	32A	40	115	90	4-15	16	190	95	215	8.23
	40A	40	120	95	4-15	16	190	95	215	8.43
	50A	50	130	105	4-15	16	200	100	240	10.3
	65A	65	155	130	4-15	18	250	125	305	18.5
	80A	80	180	145	4-19	18	270	135	340	24
	100A	100	200	165	8-19	20	320	160	400	35.7
JIS 10K (JIS F7121)	25A	25	125	90	4-19	14	170	85	180	5.34
	32A	40	135	100	4-19	16	190	95	215	8.65
	40A	40	140	105	4-19	16	190	95	215	8.85
	50A	50	155	120	4-19	16	200	100	240	10.82
	65A	65	175	140	4-19	18	250	125	305	19.45
	80A	80	185	150	8-19	18	270	135	340	25.2
	100A	100	210	175	8-19	20	320	160	400	37.5

- Remark : 1. The flanges shall conform to nominal pressure 5K and 10K of JIS B 2210.
2. The diameter and pitch of strainer cylinder holes shall be 8mm and 11mm.
3. The total area of filtering holes shall be approximately 4 times or more the area of inlet part after galvanizing.